

F-1720 TYPE (SUPERSEDES F-1620 TYPE)

USED WITH FSC
AND FSV TYPE
MOTORS

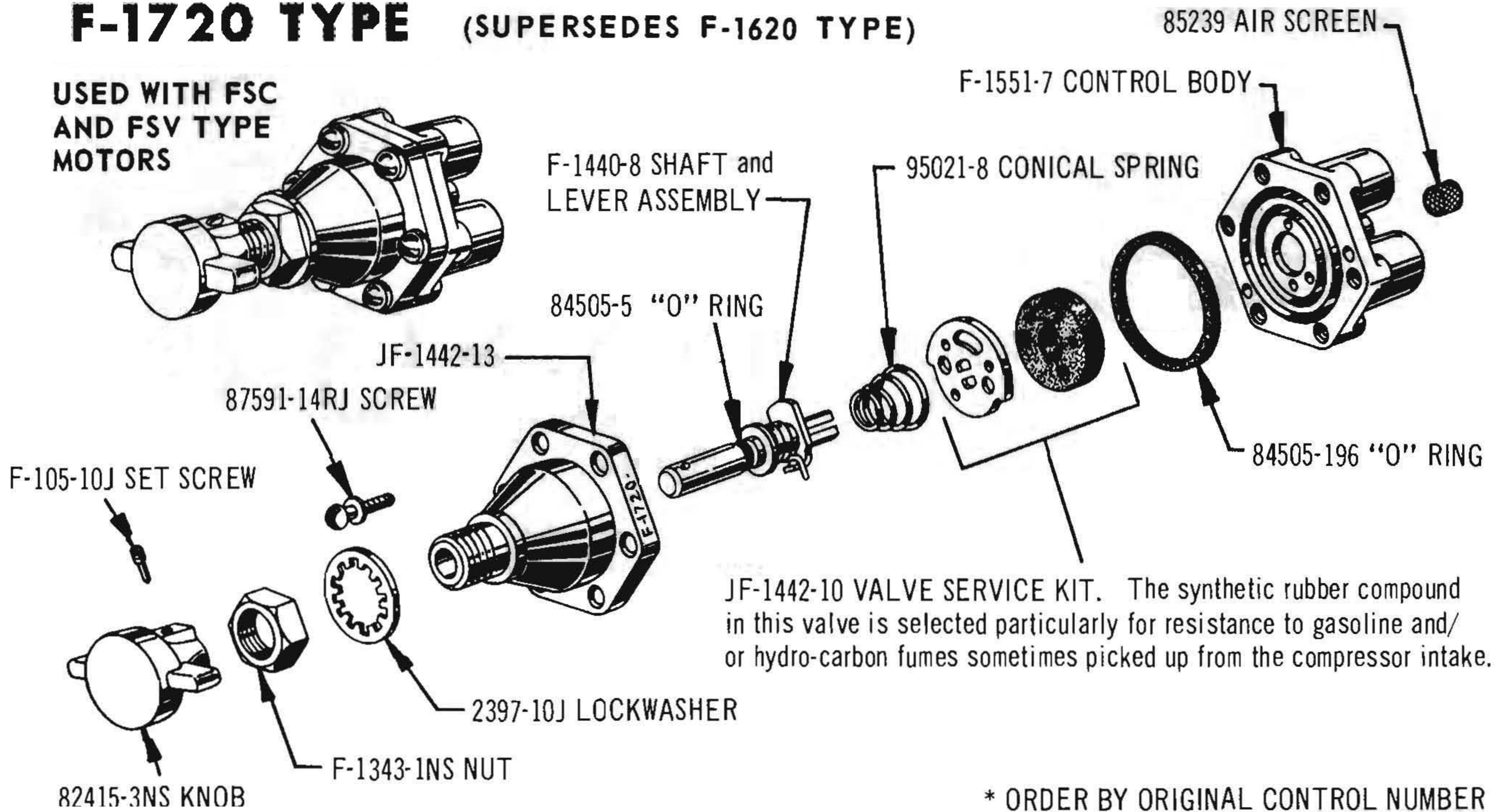

F-1620 TYPE

USED WITH FSC AND
FSV TYPE MOTORS

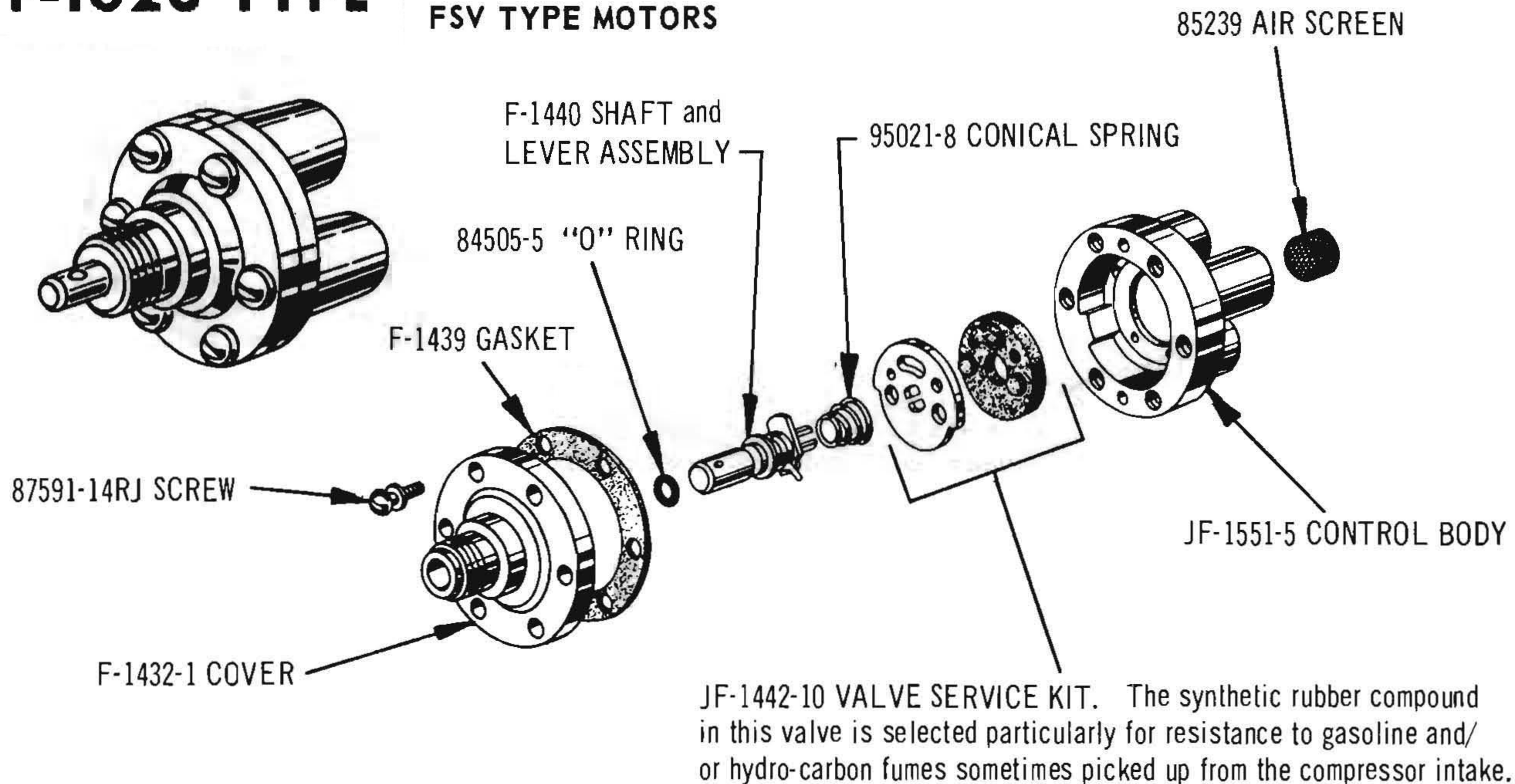

TO CHECK CONTROL VALVE:

Connect air supply line to "IN" port and turn control on. If air flows from the "RUN" port only the control is operating properly. If air flows from the "PARK" port as well as the "RUN" port, the rubber slide valve is defective.

TO REPLACE SLIDE VALVE:

Remove the control cover and discard the gasket (or "O" ring), rubber valve and backing plate. Using valve service kit, assemble new pre-greased valve to backing plate and place in valve cavity in correct position to receive control stem. Note: Be sure to replace old valve with new valve of the same thickness. If additional grease is required, use silicone grease type GE-SS-4067, or DC-4. Install new gasket (or "O" ring) and replace control valve cover. Tighten all screws securely and recheck control.

TRICO PRODUCTS CORPORATION BUFFALO, N.Y. 14203