

SERVICE BULLETIN

KENWORTH WIPER MOTOR CONVERSION

INSTRUCTIONS TO REPLACE SPRAGUE MOTOR E-008-004 WITH MOTOR E-008-037 FOR FLAT GLASS CABS BUILT PRIOR TO MAY 1992.

CAUTION - ALWAYS DISCONNECT ELECTRICAL CONNECTOR FROM THE VEHICLE WIRING HARNESS BEFORE DOING ANY WORK ON THE WIPER MOTOR. THE WIPER MOTOR PARK CIRCUIT CAN CAUSE LINKAGE TO MOVE WITHOUT WARNING IF THE WIRING IS CONNECTED.

1. REMOVE OLD WIPER MOTOR.
2. DRILL THREE MOUNTING BOLT HOLES IN WIPER BRACKET FROM FRONT OF BRACKET. USE TEMPLATE FOR FLAT GLASS MODELS.
3. ASSEMBLE NEW MOTOR TO BRACKET WITH NEW BOLTS SUPPLIED WITH MOTOR. DO NOT USE BOLTS FROM OLD MOTOR -THREAD SIZE IS METRIC. USE LOCTITE 242 (OR EQUIVALENT) ON THREADS AND TORQUE TO 60-70 INCH POUNDS.
4. INSTALL LINKAGE ON MOTOR SHAFT AS SHOWN IN DIAGRAM BELOW. MOTOR CRANK LEVER MUST BE IN LINE WITH CONNECTING LINK. HOLD MOTOR CRANK LEVER WHILE TIGHTENING FLANGED LOCK NUT ON MOTOR SHAFT TO 200 INCH POUNDS.

CAUTION - DO NOT ALLOW MOTOR CRANK TO TURN WHILE TIGHTENING NUT OR WIPERS WILL NOT PARK CORRECTLY. THE NEW WIPER MOTOR IS SHIPPED IN PARK POSITION. IF SYSTEM PARKS IN THE WRONG POSITION, REMOVE ELECTRICAL HARNESS AND DISCONNECT MOTOR CRANK. RE-CONNECT LINKAGE AS DESCRIBED IN STEP 4.

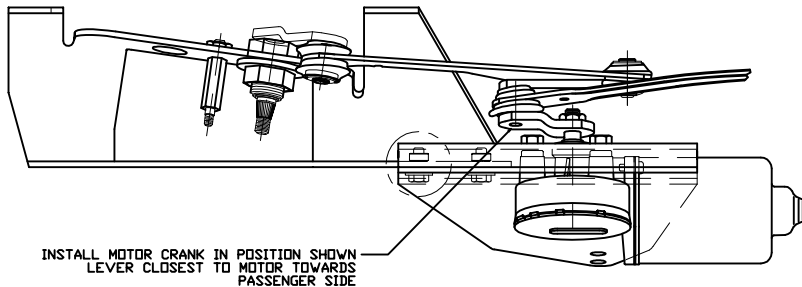

TOP VIEW OF MOTOR

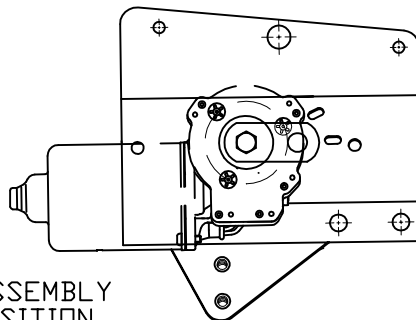

FRONT VIEW OF MOTOR ASSEMBLY
CRANK SHOWN IN PARK POSITION

FORM: #9189

REV: E

DATE: 4/04

SERVICE BULLETIN

2 OF 5

KENWORTH WIPER MOTOR CONVERSION

INSTRUCTIONS TO REPLACE SPRAGUE MOTOR E-008-004 WITH MOTOR E-008-037 FOR T-602, 1 PIECE GLASS CABS BUILT PRIOR TO MAY 1992.

CAUTION - ALWAYS DISCONNECT ELECTRICAL CONNECTOR FROM THE VEHICLE WIRING HARNESS BEFORE DOING ANY WORK ON THE WIPER MOTOR. THE WIPER MOTOR PARK CIRCUIT CAN CAUSE LINKAGE TO MOVE WITHOUT WARNING IF THE WIRING IS CONNECTED.

1. REMOVE WIPER ASSEMBLY FROM TRUCK.
2. REMOVE OLD WIPER MOTOR.
3. DRILL TWO MOUNTING BOLT HOLES IN WIPER BRACKET FROM FRONT OF BRACKET. USE TEMPLATE FOR CURVED GLASS MODELS.
4. DRILL MOUNTING BOLT HOLE IN WIPER BRACKET FROM MOTOR SIDE OF BRACKET. USE TEMPLATE FOR CURVED GLASS MODELS.
5. ASSEMBLE NEW MOTOR TO BRACKET WITH NEW BOLTS SUPPLIED WITH MOTOR. DO NOT USE BOLTS FROM OLD MOTOR - THREAD SIZE IS METRIC. USE LOCTITE 242 (OR EQUIVALENT) ON THREADS AND TORQUE TO 60-70 INCH POUNDS.
6. INSTALL LINKAGE ON MOTOR SHAFT AS SHOWN IN DIAGRAM BELOW. MOTOR CRANK LEVER MUST BE IN LINE WITH CONNECTING LINK. HOLD MOTOR CRANK LEVER WHILE TIGHTENING FLANGED LOCK NUT ON MOTOR SHAFT TO 200 INCH POUNDS.

CAUTION - DO NOT ALLOW MOTOR CRANK TO TURN WHILE TIGHTENING NUT OR WIPERS WILL NOT PARK CORRECTLY. THE NEW WIPER MOTOR IS SHIPPED IN PARK POSITION. IF SYSTEM PARKS IN THE WRONG POSITION, REMOVE ELECTRICAL HARNESS AND DISCONNECT MOTOR CRANK. RE-CONNECT LINKAGE AS DESCRIBED IN STEP 6.

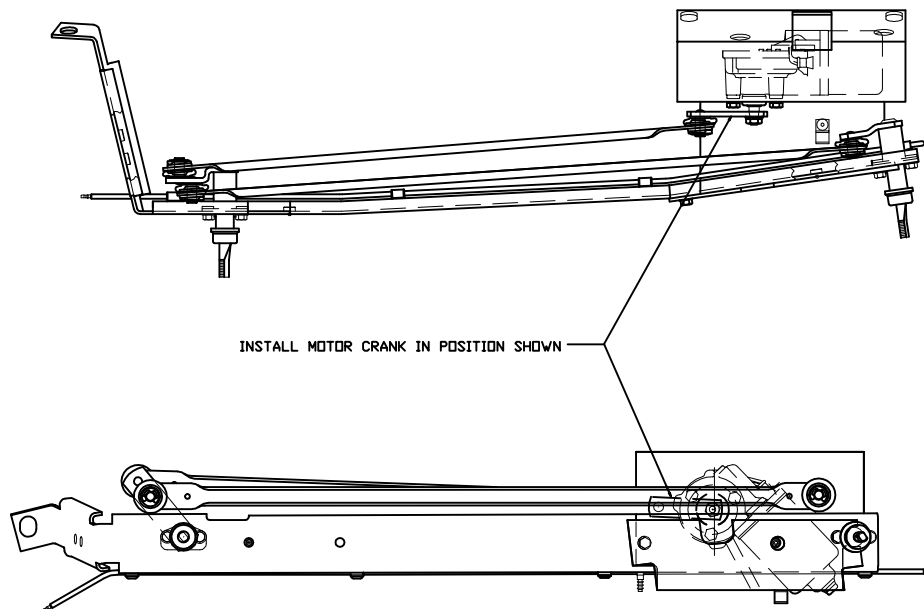

FORM: #9189

REV: E

DATE: 4/04

SERVICE BULLETIN

KENWORTH WIPER MOTOR CONVERSION

TEMPLATE FOR FLAT GLASS

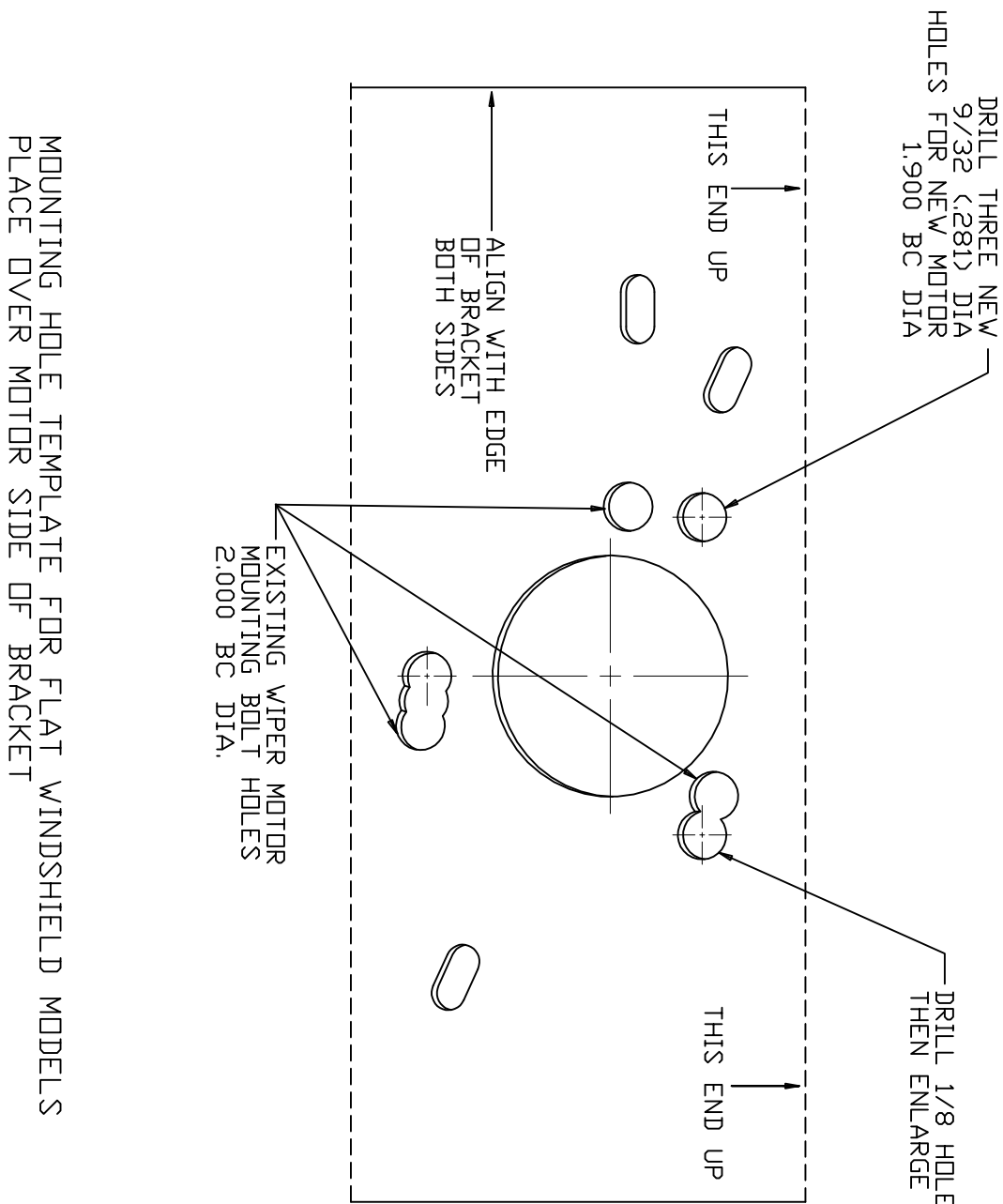

MOUNTING HOLE TEMPLATE FOR FLAT WINDSHIELD MODELS
PLACE OVER MOTOR SIDE OF BRACKET

FORM: #9189
REV: E
DATE: 4/04

SERVICE BULLETIN
KENWORTH WIPER MOTOR CONVERSION

4 OF 5

TEMPLATE FOR CURVED GLASS

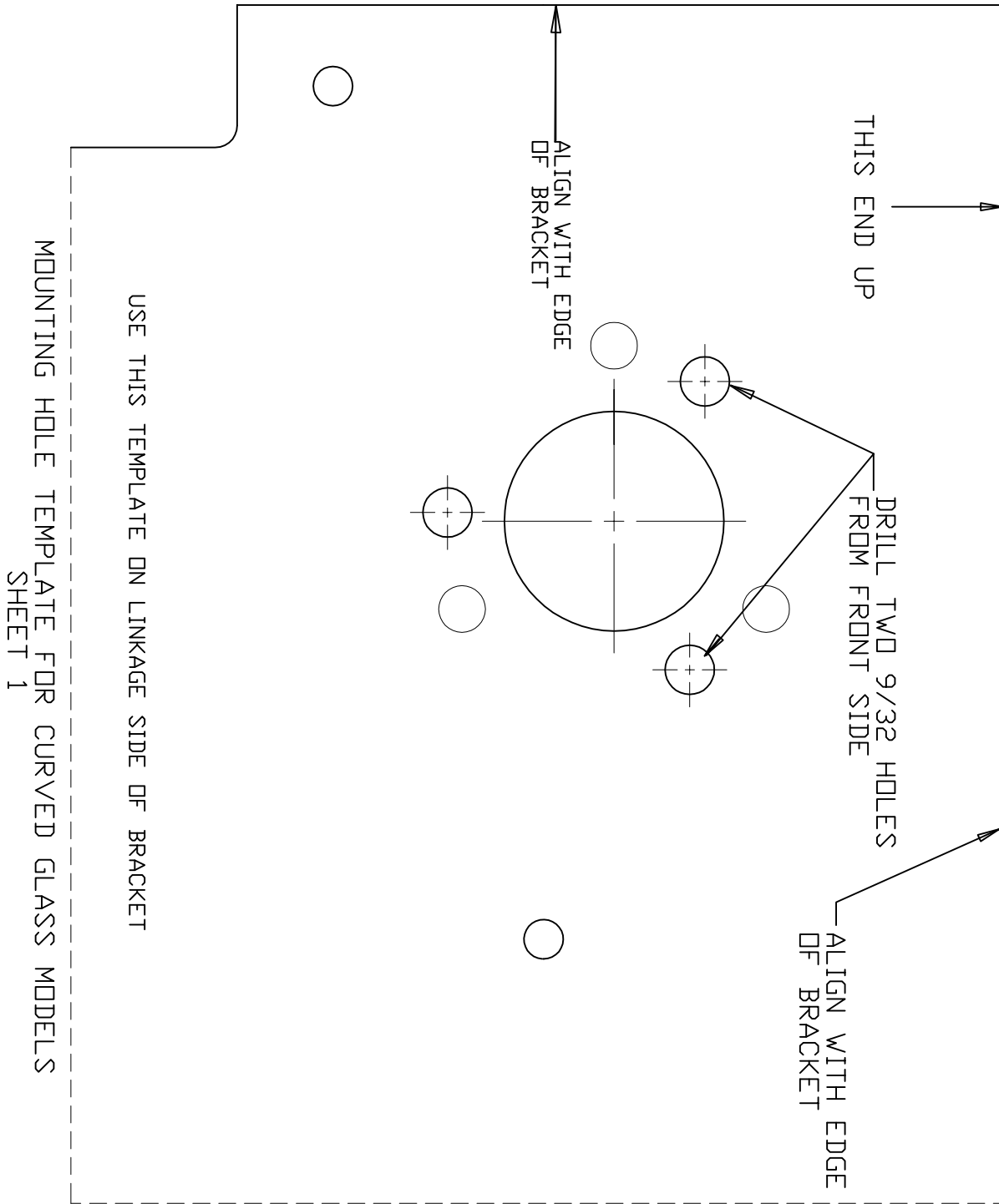

FORM:	#9189
REV:	E
DATE:	4/04

SERVICE BULLETIN
KENWORTH WIPER MOTOR CONVERSION

5 OF 5

TEMPLATE FOR CURVED GLASS

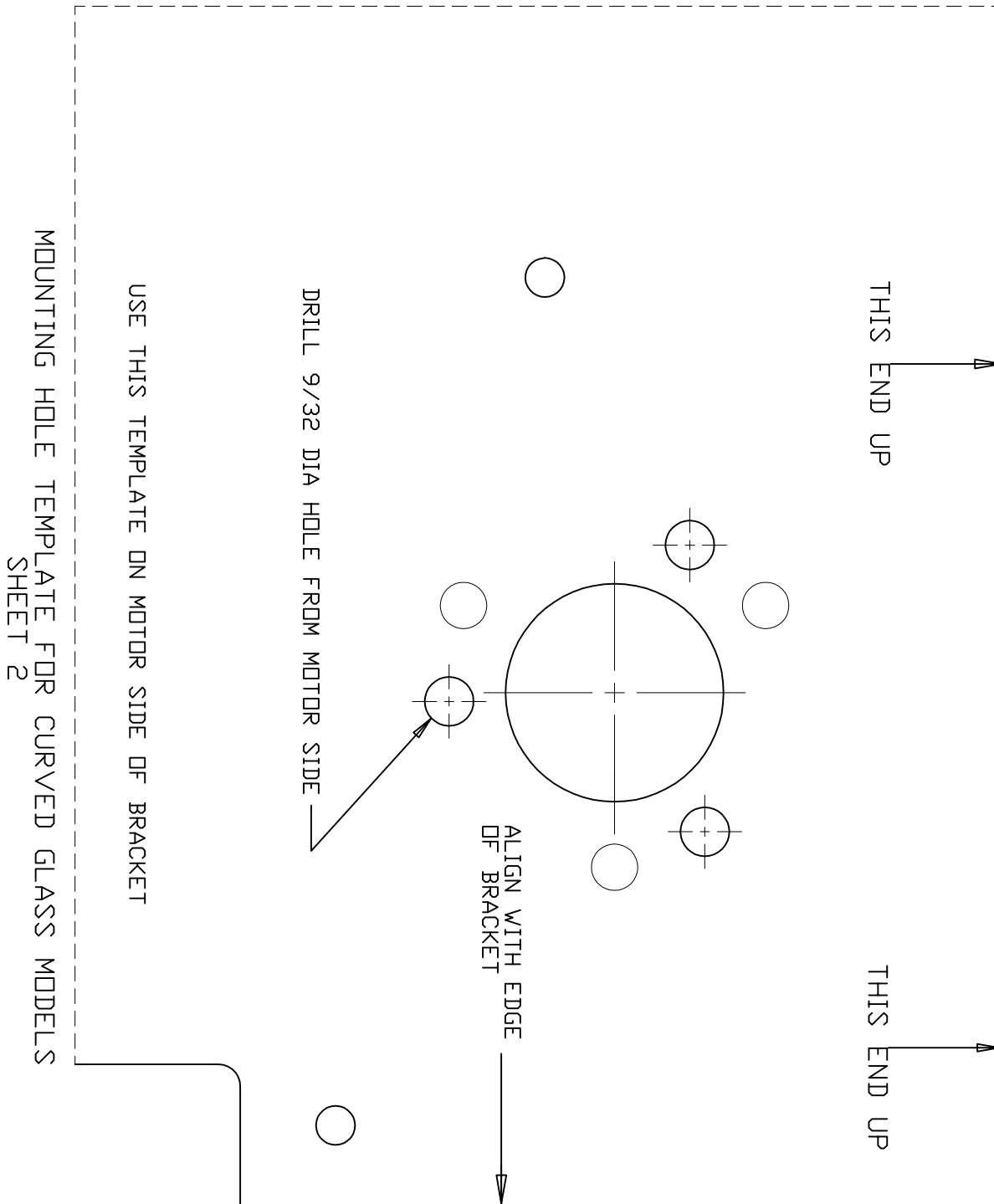

FORM: #9189
REV: E
DATE: 4/04